

REV 更改号	DATE 日期	REVISION DETAILS 更改内容	APPD 审核并批准
A	Jul. 14. 2018	Production issue	Zhang

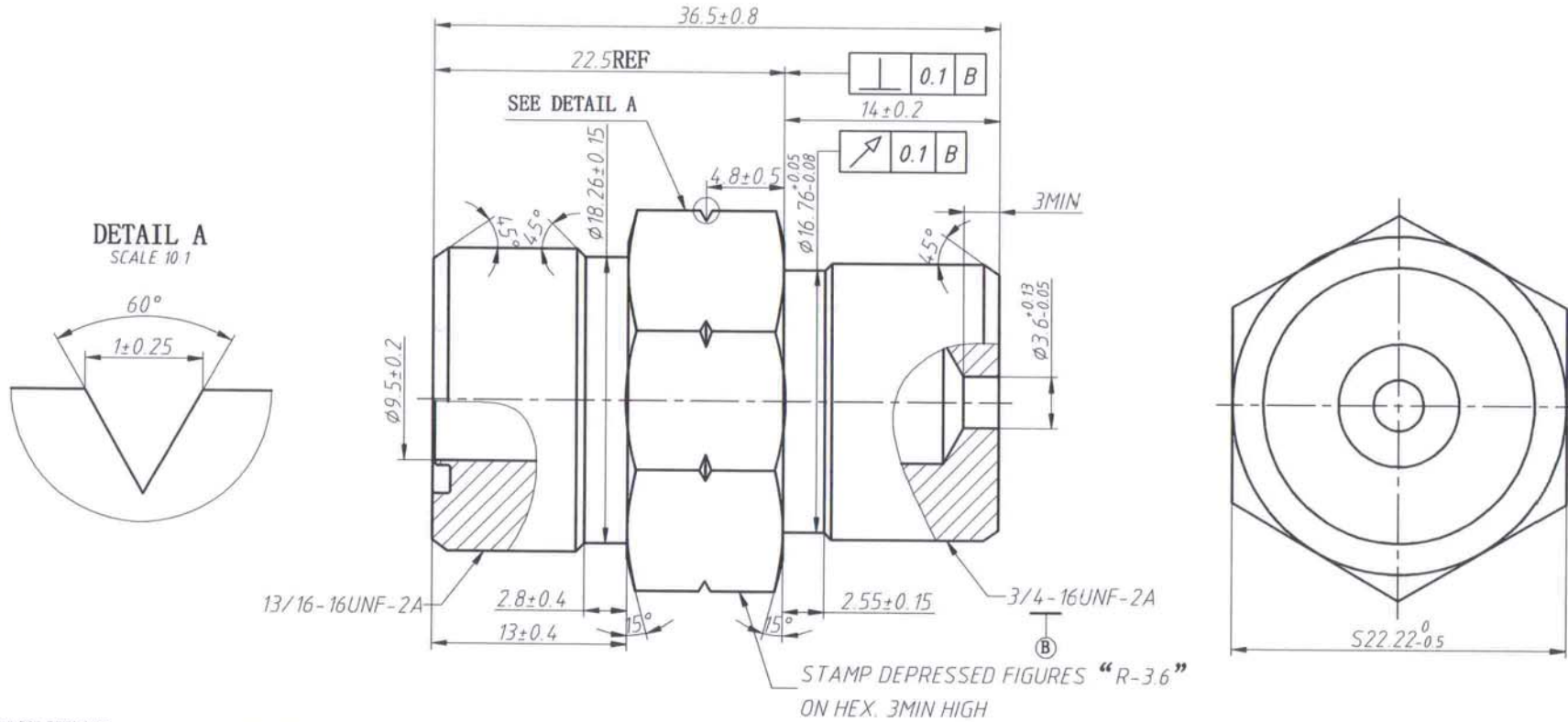

UNLESS SPECIFIED
ALL DIMENSIONS IN mm,
MACHINED SURFACES Ra=3.2um,
ANGLE TOLERANCES ±5°,
Other tolerance except angles,
in accordance with
GB/T1804-2000(ISO2768-1)-m and
GB/T1184-1996(ISO 2768-2)-m.

其它事项
图示尺寸单位为mm,
未注机加工表面粗糙度Ra=3.2um
未注角度公差±5°
其它未注公差(除角度外)均按:
GB/T1804-2000(ISO2768-1)-m 和
GB/T1184-1996(ISO2768-2)-m

Zhejiang Gaocheng Autoparts Co., Ltd			
PART NO 零件名	41321-8FS-8R3.6		
SCALE NTS	APPD: 批准 DP	DRN 制图 DS. YU	DATE 日期 2018.06.08
	DATE 日期 2017/18	CHK 审核 YB. ZHAN	DATE 日期

MATERIAL	Chinese steel 45	材质: 45#
FINISH	Remove all sharp edges, burrs, slivers and swarf, break all edges 0.127-0.254mm. ZINC PLATING WITH 8um MICRONS MINIMUM PLATING THICKNESS AND TRIVALENT CHROMATE PASSIVATION AND WITHSTAND 96 HS TO WHITE / 144 HS TO RED RUST IN SALT SPRAY TEST.	去除所有毛刺, 铁屑等残留物, 锐边倒钝0.127-0.254mm. 镀锌, 三价铬钝化, 银白色, 盐雾试验96小时无白斑, 144小时无红锈, 镀锌层厚度大于8um.